

# DB3-B775 · B776

Single Needle Cylinder Bed Needle Feed  
Lock Stitcher  
Single Needle Cylinder Bed Needle Feed  
Lock Stitcher with Thread Trimmer

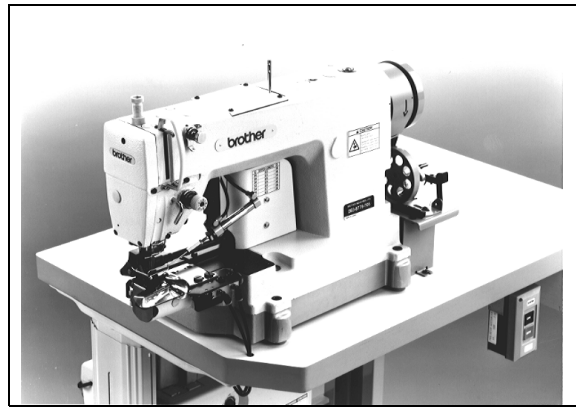

## Specifications

	B775	B776
Application	Hem bottom for jeans (Heavy materials)	
Max. sewing speed	5,000 rpm	
Stitch length	2 - 4.2 mm	
Needle bar stroke	33 mm	
Height of presser foot	14 mm	
Needle	1955 - 01MR5	
Hook	× 1.7 Rotary hook	
Cylinder circumference	180 mm	
Hem size	12.7 mm (1 / 2")	
Power source	-	Single phase 110 V, 220 V, 230 V, 240 V 3-phase 220 V, 380 V, 400 V, 415 V
Air pressure · Air consumption	-	0.49 Mpa (5 kgf / c m <sup>2</sup> ) · 0.5 l / min
Production capacity	1,000 - 1,200 pieces/day (2,000 - 2,400 seams)	

# Presser foot mechanism

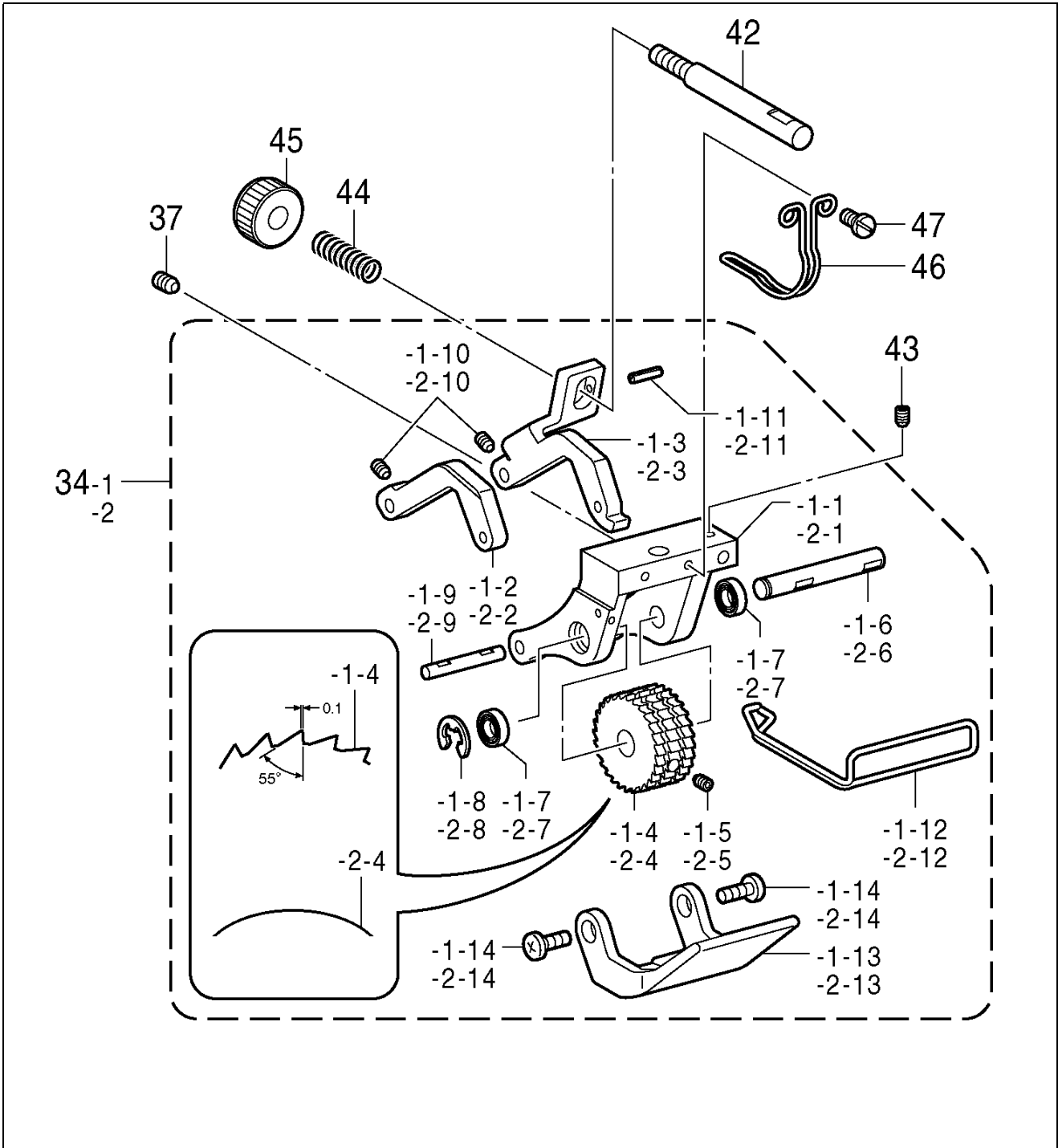

## Presser foot mechanism

<For thin materials>

<Gear type>

Ref. No.	Part name	Part code	Q'ty
34-1	Presser foot assy, 12.7	S47629-101	1
34-1-1	Presser bracket	S44040-001	1
34-1-2	Presser foot, UL	S51239-001	1
34-1-3	Presser foot, UR	S51240-001	1
34-1-4	Roller, 28	S47639-001	1
34-1-5	Set screw, socket (CP) SM4.37	014680-622	2
34-1-6	Roller shaft	S44044-001	1
34-1-7	Ball bearing	S44045-000	2
34-1-8	Retaining ring, E5	048050-342	1
34-1-9	Presser foot shaft	S44046-001	1
34-1-10	Set screw, socket (CP) M3x5	014300-532	2
34-1-11	Pin, spring roll AW2	047201-042	1
34-1-12	Finger guard	S44047-000	1
34-1-13	Presser foot, D 12.7	S44048-001	1
34-1-14	Screw, bind SM3.18 - 40 x 6	060660-612	2
37	Set screw, socket SM5.95	014760-622	1
42	Shaft	S44050-001	1
43	Set screw, socket (CP) SM4.37	014680-422	1
44	Spring	S44051-001	1
45	Tension nut	155510-001	1
46	Roller cover	S44052-001	1
47	Screw, SM 3.57 x 6	100257-010	2

<Rubber roller type >

Ref. No.	Part name	Part code	Q'ty
34-2	Presser foot assy, 12.7	S47630-101	1
34-2-1	Presser bracket	S44040-001	1
34-2-2	Presser foot, UL	S51239-001	1
34-2-3	Presser foot, UR	S51240-001	1
34-2-4	Rubber roller, 28	S47635-001	1
34-2-5	Set screw, socket (CP) SM4.37	014680-622	2
34-2-6	Roller shaft	S44044-001	1
34-2-7	Ball bearing	S44045-000	2
34-2-8	Retaining ring, E5	048050-342	1
34-2-9	Presser foot shaft	S44046-001	1
34-2-10	Set screw, socket (CP) M3x5	014300-532	2
34-2-11	Pin, spring roll AW2	047201-042	1
34-2-12	Finger guard	S44047-000	1
34-2-13	Presser foot, D 12.7	S44048-001	1
34-2-14	Screw, bind SM3.18 - 40 x 6	060660-612	2
37	Set screw, socket SM5.95	014760-622	1
42	Shaft	S44050-001	1
43	Set screw, socket (CP) SM4.37	014680-422	1
44	Spring	S44051-001	1
45	Tension nut	155510-001	1

# Presser foot mechanism

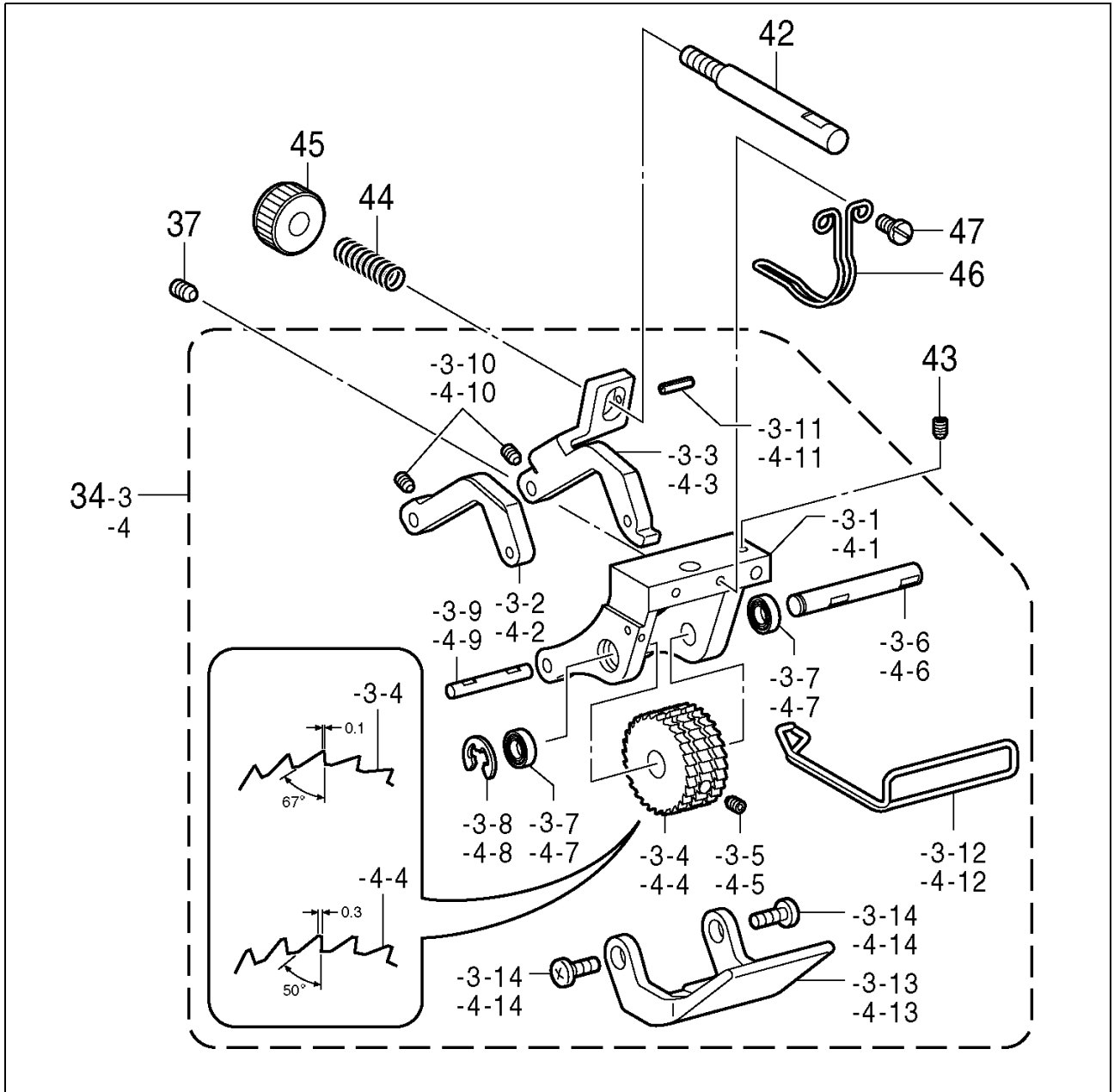

## Presser foot mechanism

<For medium materials>

Ref. No.	Part name	Part code	Q'ty
34-3	Presser foot assy, 12.7	S46429-101	1
34-3-1	Presser bracket	S44040-001	1
34-3-2	Presser foot, UL	S51239-001	1
34-3-3	Presser foot, UR	S51240-001	1
34-3-4	Roller, 28	S44043-001	1
34-3-5	Set screw, socket (CP) SM4.37	014680-622	2
34-3-6	Roller shaft	S44044-001	1
34-3-7	Ball bearing	S44045-000	2
34-3-8	Retaining ring, E5	048050-342	1
34-3-9	Presser foot shaft	S44046-001	1
34-3-10	Set screw, socket (CP) M3×5	014300-532	2
34-3-11	Pin, spring roll AW2	047201-042	1
34-3-12	Finger guard	S44047-000	1
34-3-13	Presser foot, D12.7	S44048-001	1
34-3-14	Screw, bind SM3.18-40×6	060660-612	2
37	Set screw, socket SM5.95	014760-622	1
42	Shaft	S44050-001	1
43	Set screw, socket (CP) SM4.37	014680-422	1
44	Spring	S44051-001	1
45	Tension nut	155510-001	1
46	Roller cover	S44052-001	1
47	Screw, SM 3.57 × 6	100257-010	2

<For heavy materials>

Ref. No.	Part name	Part code	Q'ty
34-4	Presser foot assy, 12.7	S46766-101	1
34-4-1	Presser bracket	S44040-001	1
34-4-2	Presser foot, UL	S51239-001	1
34-4-3	Presser foot, UR	S51240-001	1
34-4-4	Roller, 28	S46767-001	1
34-4-5	Set screw, socket (CP) SM4.37	014680-622	2
34-4-6	Roller shaft	S44044-001	1
34-4-7	Ball bearing	S44045-000	2
34-4-8	Retaining ring, E5	048050-342	1
34-4-9	Presser foot shaft	S44046-001	1
34-4-10	Set screw, socket (CP) M3×5	014300-532	2
34-4-11	Pin, spring roll AW2	047201-042	1
34-4-12	Finger guard	S44047-000	1
34-4-13	Presser foot, D 12.7	S44048-001	1
34-4-14	Screw, bind SM3.18 - 40 × 6	060660-612	2
37	Set screw, socket SM5.95	014760-622	1
42	Shaft	S44050-001	1
43	Set screw, socket (CP) SM4.37	014680-422	1
44	Spring	S44051-001	1
45	Tension nut	155510-001	1
46	Roller cover	S44052-001	1
47	Screw, SM 3.57 × 6	100257-010	2

## Presser foot mechanism

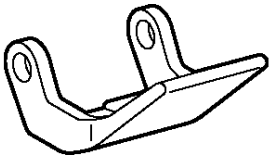
			
Part name	Part code	Q'ty	
Presser foot, D9.5	S44049-001	1	

## Needle plate

<For B776>

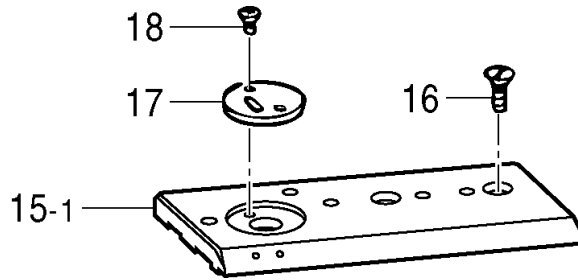

Ref. No.	Part name	Part code	Q'ty
15-1	Needle plate	S44018-001	1
16	Screw, flat SM4.37	100032-004	2
17	Needle hole plate	S44019-001	1
18	Screw, flat SM2.38	100360-003	2
	<For thin materials >		
17	Needle hole plate	S47634-001	1

<For B775>

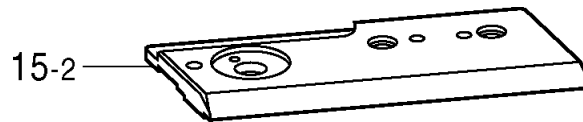

Ref. No.	Part name	Part code	Q'ty
15-2	Needle plate	S46310-001	1

\*Screw, flat SM4.37, needle hole plate, and screw, flat SM2.38 are used for both B775 & B776.

## Feed roller

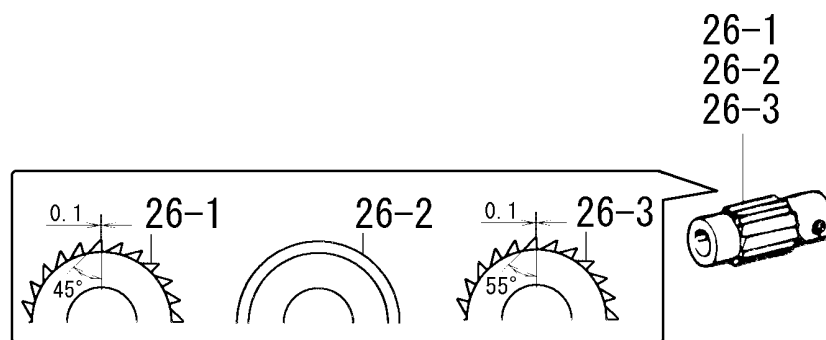

Ref. No.	Part name	Part code	Q'ty
	<b>For thin materials</b>		
	<Gear type >		
26-1	Roller, 14	S47640-001	1
	<Rubber roller type >		
26-2	Rubber roller, 14	S47636-001	1
	<b>For medium and heavy materials</b>		
26-3	Roller, 14	S44088-001	1

# Lapper mechanism

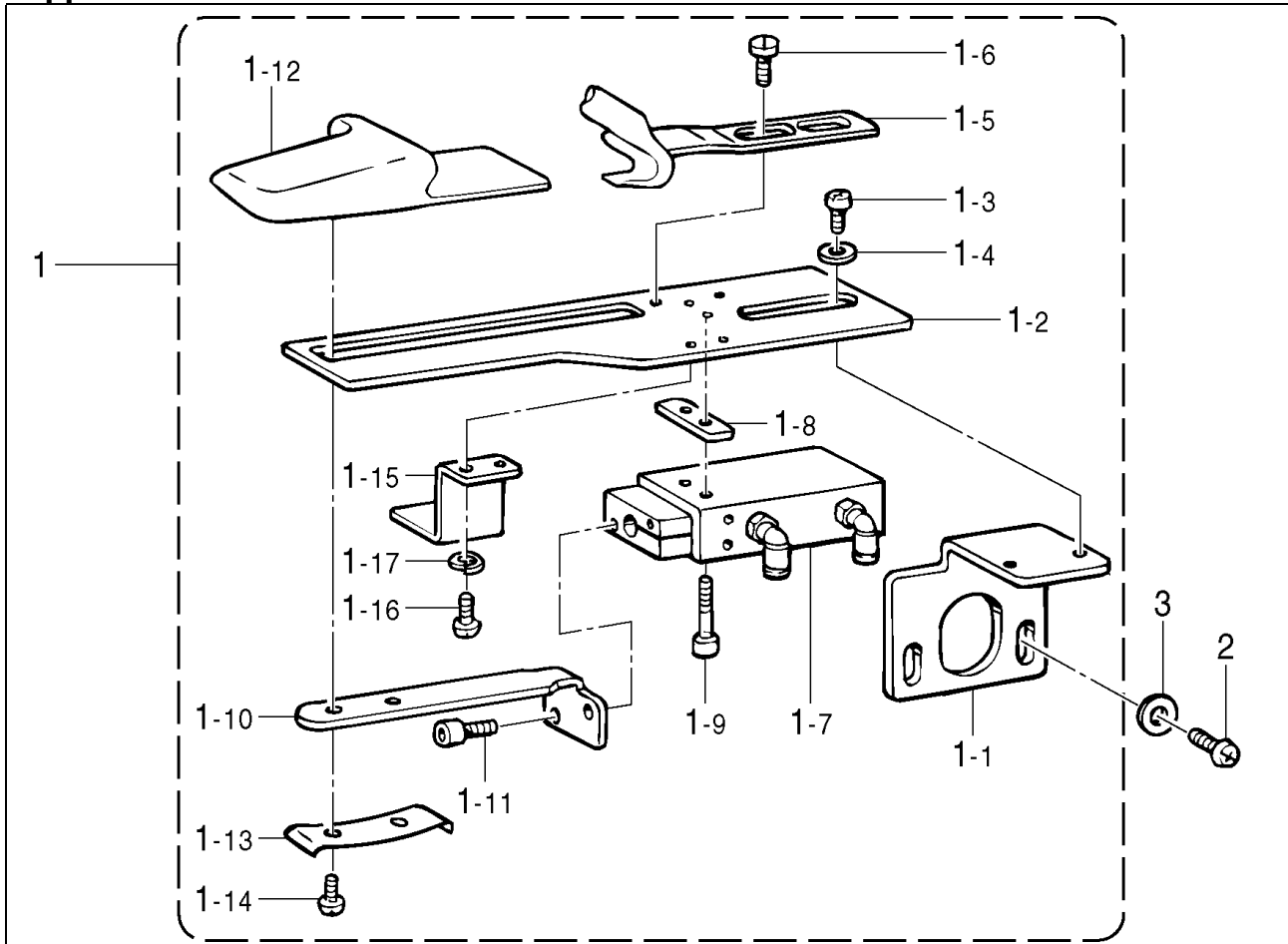

Ref. No.	Part name	Part code	Q'ty
<b>&lt;For heavy materials&gt;</b>			
1	Lap seam folder assy	S44095-001	1
1-1	Lap seam folder support plate	S44096-001	1
1-2	Lap seam folder setting plate	S44097-001	1
1-3	Screw, pan SM4.37 - 40 x 8	062680-812	2
1-4	Washer, plain 5	146354-001	2
1-5	Lap seam folder, R	S44098-000	1
1-6	Screw, SM4.37	115503-001	2
1-7	Cylinder assy	S44099-000	1
1-8	Spacer	S44101-001	1
1-9	Bolt, socket M3 x 16	018301-636	2
1-10	Guide plate, folder (L)	S44102-001	1
1-11	Bolt, socket M3 x 10	018301-036	2
1-12	Lap seam folder, L	S44103-000	1
1-13	Presser plate	S44104-001	1
1-14	Screw, pan M3 x 8	062300-816	2
1-15	Cover	S44105-001	1
1-16	Screw, pan M3 x 4	062300-416	2
1-17	Washer, spring 2 - 3	028030-242	2
2	Screw, pan SM5.95 - 28 x 12	062761-212	2
3	Washer, plain M6	025060-232	2
<b>&lt;For medium materials&gt;</b>			
1	Lap seam folder assy, M	S47631-001	1
1-5	Lap seam folder, RM	S47632-000	1
1-12	Lap seam folder, LM	S47633-000	1

# Needle cooler

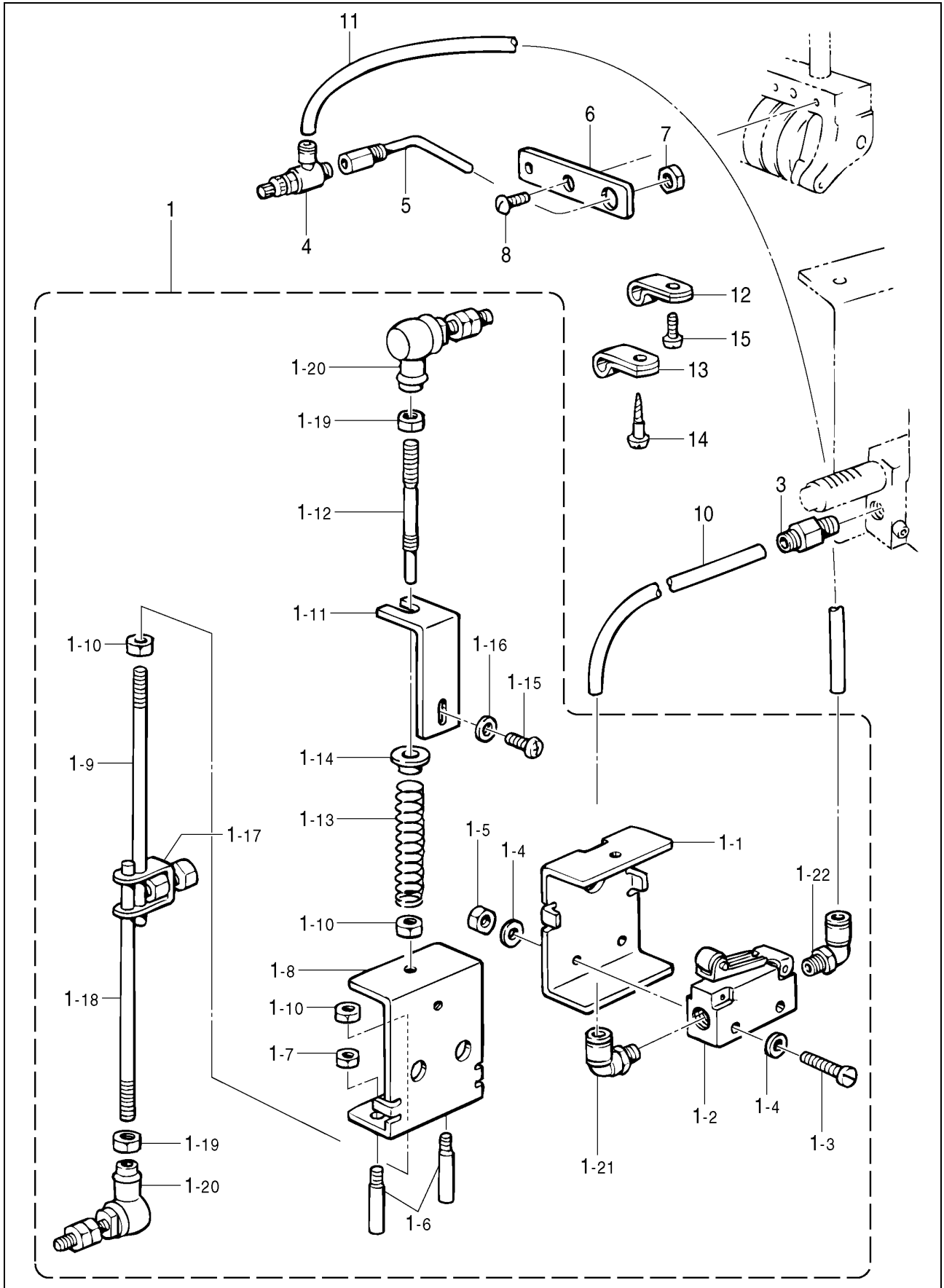



## Needle cooler

Ref. No.	Part name	Part code	Q'ty
1	Connecting rod assy	S44154-001	1
1-1	Valve setting plate	S21356-001	1
1-2	Micro valve	S01561-000	1
1-3	Screw, flat M4 × 25	007402-516	2
1-4	Washer, plain M4	025040-236	4
1-5	Nut, 1M4	021400-106	2
1-6	Pin	S21357-001	2
1-7	Nut, 2M4	021400-206	4
1-8	Valve differential plate	S21358-001	1
1-9	Connecting rod, inner	S44155-001	1
1-10	Nut, 3M6	021060-306	3
1-11	Adjusting plate, spring	S21359-001	1
1-12	Connecting rod, U	S21360-001	1
1-13	Spring, A	S21361-001	1
1-14	Spring holder	S21362-000	1
1-15	Screw, bind M4 × 6	060400-616	1
1-16	Washer, plain M4	025040-236	1
1-17	Connecting rod clamp assy	181225-001	1
1-18	Connecting rod, inner	S44155-001	1
1-19	Nut, 3M6	021060-306	2
1-20	Joint assy	119712-001	2
1-21	Elbow union, 61	S01542-000	1
1-22	Elbow union	S04909-000	1
3	Half union	S01522-000	1
4	Speed controller	S23660-000	1
5	Air blow assy	S44156-001	1
6	Air blow setting plate	S44159-001	1
7	Nut, 1M5	021500-106	1
8	Screw, bind SM3.57 – 40 × 6	060670-612	1
10	Air tube, 6L = 900	S28686-000	1
11	Air tube, L = 1170	S36655-001	1
12	Cord holder, 6N	525664-000	1
13	Cord holder, 5N	S00480-000	1
14	Wood screw, round M3.1 × 13	031311-302	1
15	Screw, pan SM3.57 – 40 × 6	062670-612	1

## Thread wiper mechanism

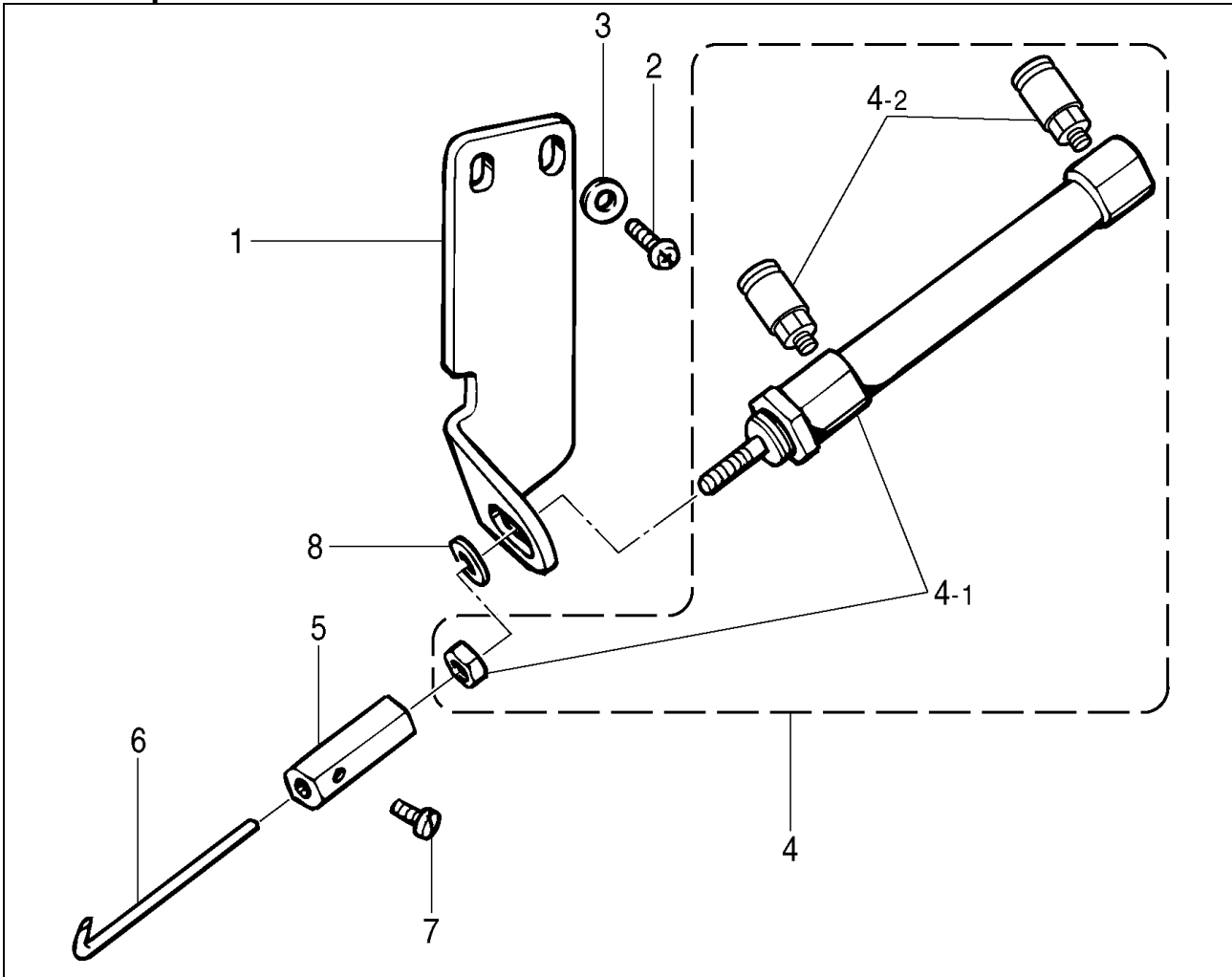

Ref. No.	Part name	Part code	Q'ty
1	Setting bracket, cylinder	S44139-001	1
2	Screw, pan SM4.37 - 40 × 10	062681-012	2
3	Washer, plain S4.37	025680-132	2
4	Cylinder assy, 10 × 30	S41581-000	1
4-1	Cylinder 10 × 30	S41582-000	1
4-2	Tube elbow, M - 5HL - 4	S12150-000	2
5	Thread wiper arm	S44140-001	1
6	Thread wiper	S44141-001	1
7	Set screw, SM3.18	140553-102	1
8	Washer, plain S10	025100-132	1